

UNCONTROLLED IF PRINTED; CONTROLLED DOCUMENT LOCATED IN IQMS DOCUMENT CONTROL

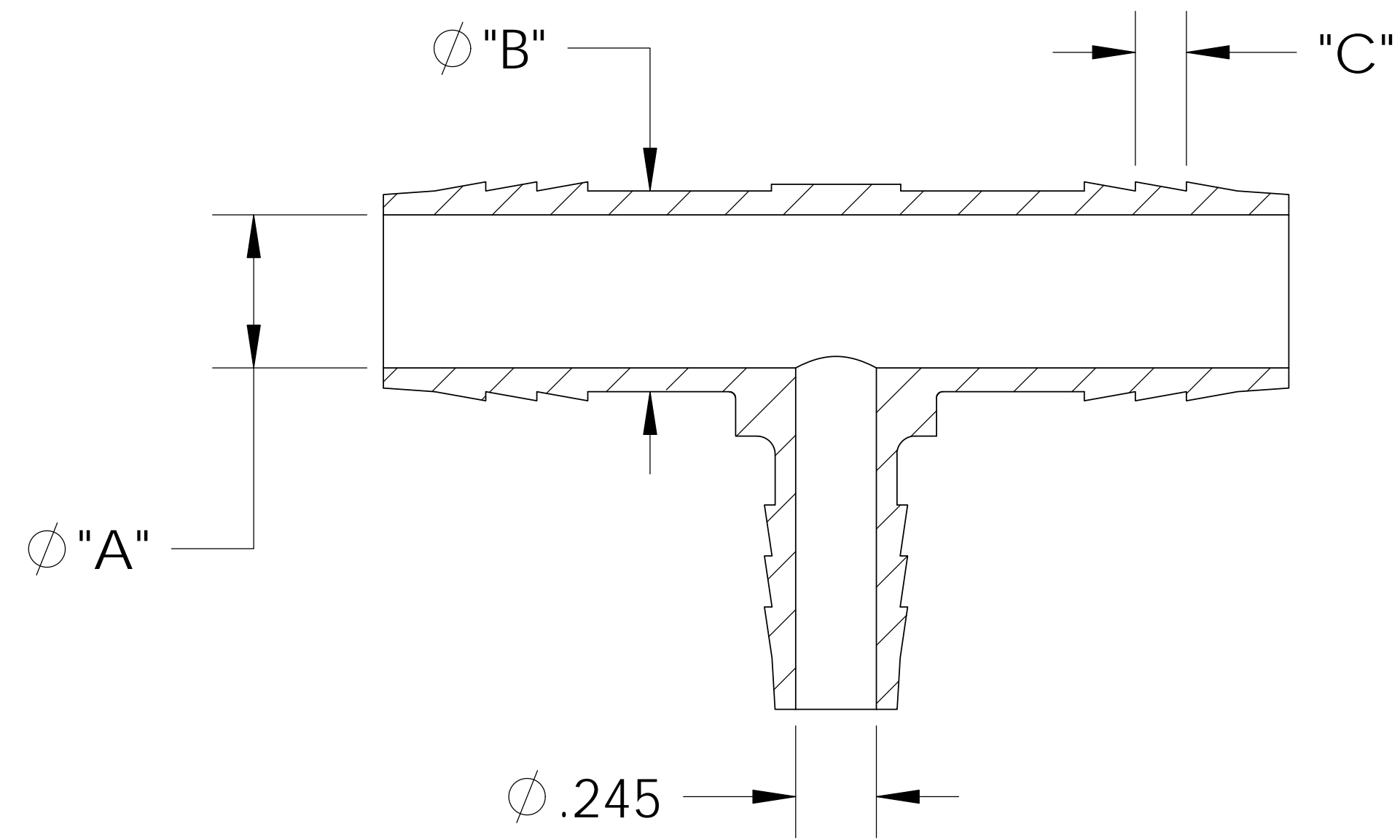

SECTION A-A

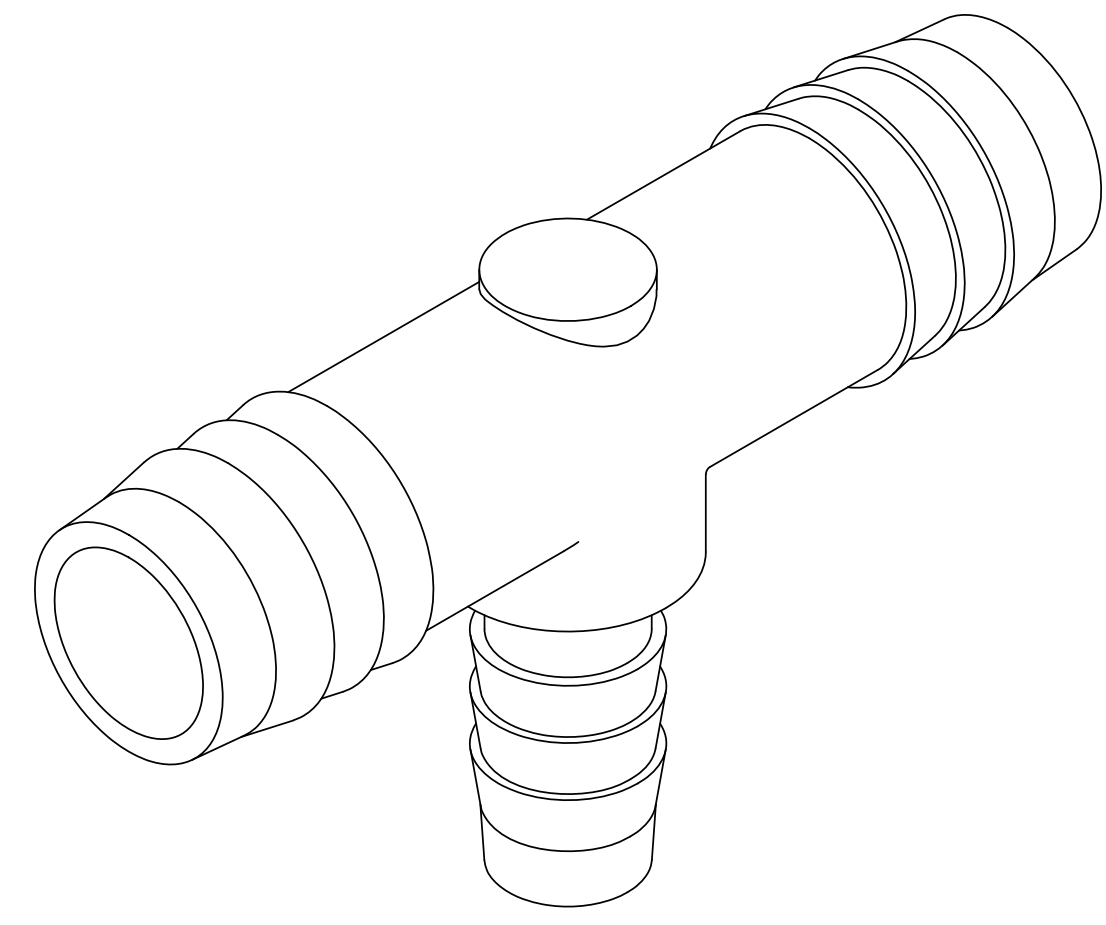
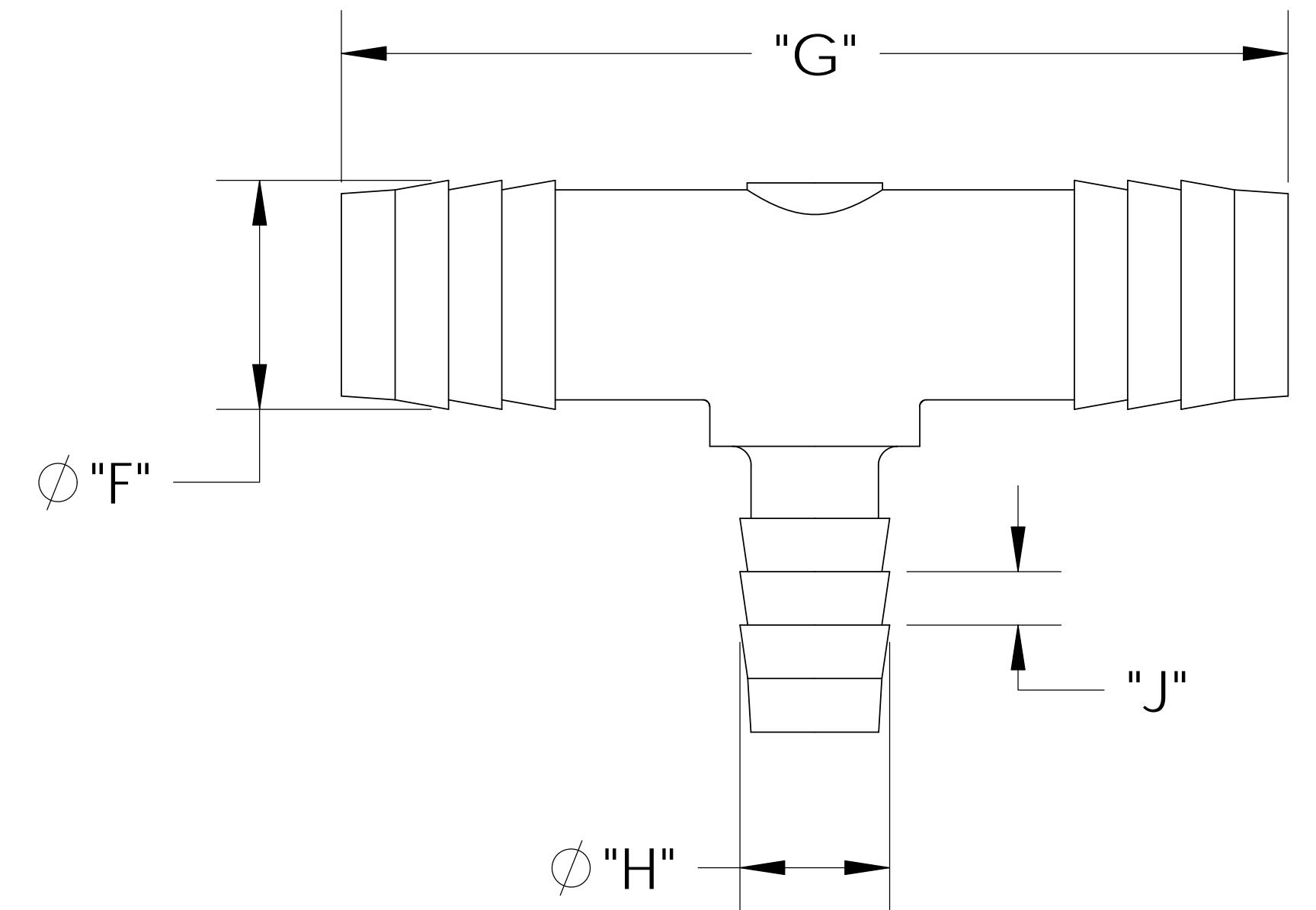
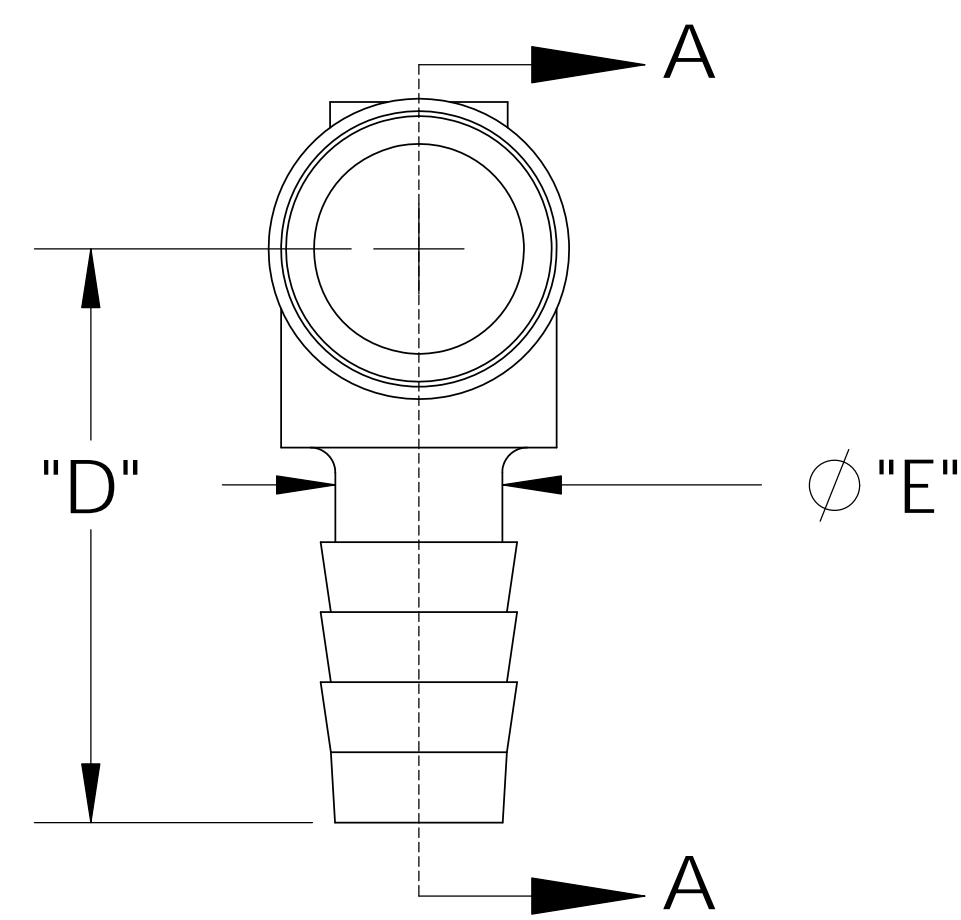

CATALOG NO.	DESCRIPTION	MATERIAL	DIM "A"	DIM "B"	DIM "C"	DIM "D"	DIM "E"	DIM "F"	DIM "G"	DIM "H"	DIM "J"
TT961010/PP	3/8 X 5/8 X 5/8 PP	POLYPROPYLENE	.460	.605	.155	1.21	.365	.665	2.72	.425	.155
TT961010/P	3/8 X 5/8 X 5/8 P	POLYETHYLENE	.455	.605	.145	1.27	.370	.650	2.66	.430	.145
TT961010/N	3/8 X 5/8 X 5/8 N	NYLON	.465	.610	.155	1.27	.370	.665	2.75	.435	.155

SHOWN

NOTES:

- POLYPROPYLENE HAS COLOR OPTIONS:
BLACK = TT961010/PPB
NATURAL = TT961010/PPN

PROPRIETARY AND CONFIDENTIAL
THE INFORMATION CONTAINED IN THIS DRAWING IS THE SOLE PROPERTY OF THOGUS PRODUCTS COMPANY. ANY REPRODUCTION IN PART OR AS A WHOLE WITHOUT THE WRITTEN PERMISSION OF THOGUS PRODUCTS COMPANY IS PROHIBITED.

REV	WRO#	DESCRIPTION
E	95.00053	CONVERTED TO 3D FORMAT

UNLESS OTHERWISE SPECIFIED:
DIMENSIONS ARE IN INCHES
TOLERANCES:
ANGULAR: $\pm 0.5^\circ$
X.X = ± 0.1
X.XX = ± 0.05
X.XXX = ± 0.015
REMOVE ALL SHARP EDGES AND BURRS
BLEND ALL RADII TO 0.01IN
INTERPRET GEOMETRIC TOLERANCING PER: ANSI Y 14.5 1994
MATERIAL: PP, P, N
FINISH: NA
THIRD ANGLE PROJECTION:

	NAME	DATE
DRAWN	KDJ	12/21/10
CHECKED	KDJ	12/21/10
ENG APPR.		XX/XX/XX
MFG APPR.		XX/XX/XX
Q.A.		XX/XX/XX

Thogus You think it, we can make it...
33490 PIN OAK, AVON LAKE, OH 44012

TITLE:
3/8 BARB X 5/8 BARB X 5/8 BARB TEE

SIZE B	DWG. NO. TT961010	REV E
------------------	----------------------	-----------------

DO NOT SCALE DRAWING

SCALE: 1:1

MASS:

SHEET 1 OF 1